

# WH-16

## CNC 2POINT COILING MACHINE

Very Cost-effective 7-Axis 2-Point coiling machine

Available for wire dia. 1.6mm at max.

High production speed, High precision, & Short setup time

Easy Programming with pre-installed application software dedicated to compression spring part



### ORII & MEC CORPORATION

1-17-24 Kamiaoki-Nishi Kawaguchi-shi Saitama 333-0845 Japan  
TEL: (81) 48-256-3511 FAX: (81) 48-256-3595  
<http://www.oriimec.co.jp/> e-mail: [info-spring@oriimec.co.jp](mailto:info-spring@oriimec.co.jp)

**Features**

- 7-Axis for Feed, Cut, Wedge-Pitch, 1<sup>st</sup> Point, 2<sup>nd</sup> Point, Push-Pitch, & Arbor back-and-forth equipped as standard.
- Twin-roller applied for feed can reduce feed pressure on wire material. Feed pressure can be managed with setup record unit (option).
- Easy switching to Rotary cut, Straight cut, or Wedge-Pitch by moving eccentric pin.
- Cut, Wedge-Pitch, and Arbor equipped on the center slide does not need to align arbor with cutting tool even if coil diameter is changed. Center slide position can be managed with setup record unit (option).
- No need to remove and reinstall point slide when changing winding direction.
- Program screen consists of all-axis always displayed and other cells movable by vertical scroll, and Program flow and each axis operation can be recognized with one look.
- Easy programming for pitch and outside diameter individually gives easy adjustment of compression spring. With line chart, adjustment work can be recognized visually.
- For variation of conical springs, straight, bowl and such shape can be formed adjusting in multi-step up to 100-step, and desired load can be achieved easily.
- Capacitance gage sensor comes with as a standard accessory. Production control can be done with auto-correction and multi-functional production control screen.
- Initial tension servo and Rotary point servo are applicable to 1<sup>st</sup> point and 2<sup>nd</sup> point at the options.

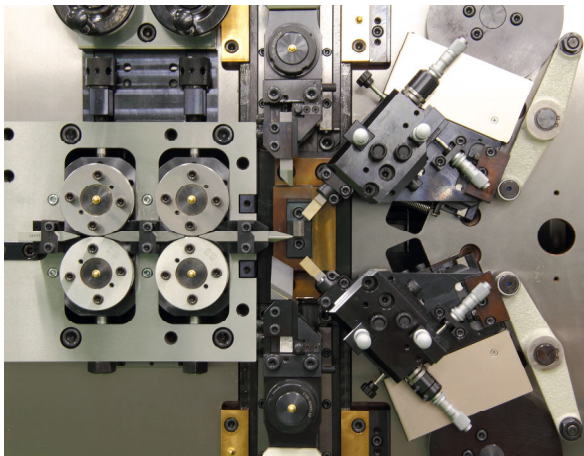

**1<sup>st</sup> point & 2<sup>nd</sup> point**

Having adjustment mechanisms for Rotational direction along with Coiling pin in/out, Bobbing and Tilting movement.

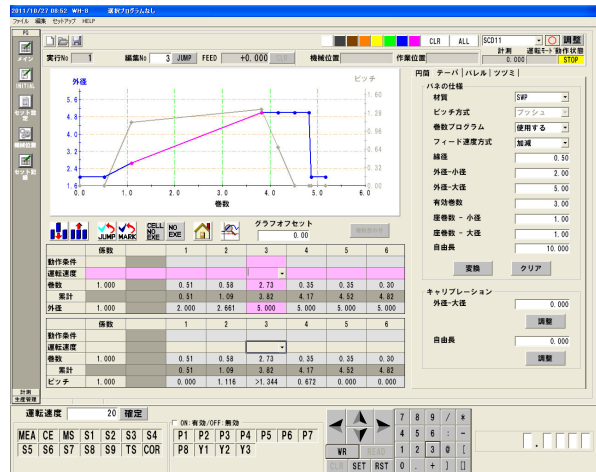

**Pitch line chart on program screen**

Setting Pitch program and Outside dia. Program respectively makes adjustment of compression spring program easier.

**Specifications**

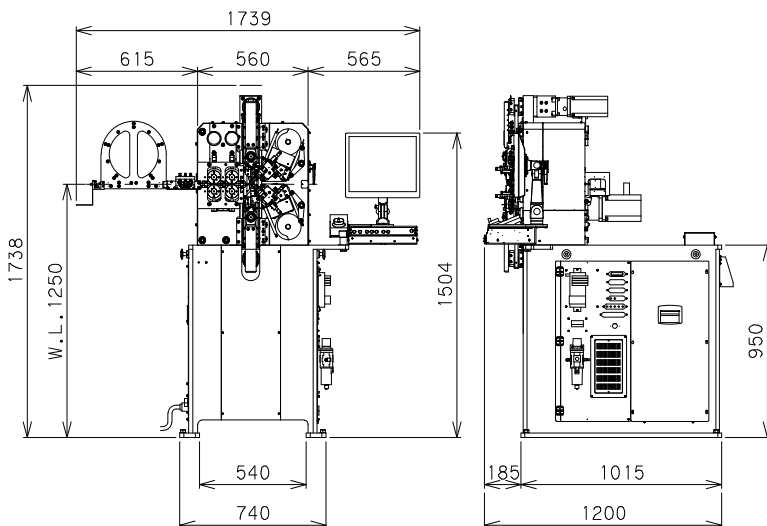

Standard Spec	Wire Dia.	φ0.5~1.6mm
	Outside Dia.	φ50mm
	D/d Index	4 or more
Feed Axis	Resolution	0.001mm
	Max. Speed	165m/min
Cut Axis	Resolution	0.001 deg
Wedge-Pitch Axis	Resolution	0.001mm
Point axis x 2	Resolution	0.001mm
Push-Pitch Axis	Resolution	0.001mm
Arbor Axis	Resolution	0.01 deg
Solenoid valves	4 pcs (8 pcs at Max.)	
Service Air Pressure	Max. 0.5 Mpa	
Power Source	3-phase AC200V, 25A	
Net Weight	1,400kg	
Control Device	OS Windows XP	
	Max. 10-axis controllable	
Display	17" TFT color LCD	
External memory	USB memory	
Service Temperature	0 ~ 40 °C	

Specifications are subject to change without notice.